

APPEARANCE

STAR N



FEATURES



ELCB safety device



High precision TBST thermostat

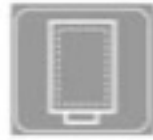

Enameled steel tested at 16 bar



Water proof protection



Temperature regulation



High precision thermostat



High density insulation



High density polyurethane insulation



Exclusive Enameled tank



Magnesium anode



Pressure safety valve



Inspection flange



Pilot lamp



High efficiency inlet pipe

low consumption
high performance

- ELCB safety device
- High Precision TBST Thermostat
- Exclusive Enameled tank protection
- Worry-free TSS Total Safety System
- Low power range for minimum consumption
- External temperature regulation
- In-house built heating element
- Large anticorrosion magnesium anode
- High efficiency insulation material
- Easy installation and maintenance



SPECIFICATION DATA

Dimension of product

STAR N

D W H

Product dimensions	NEW STAR 15	326.1 * 360 * 385.2
	NEW STAR 30	391.8 * 462 * 475.5
Carton box dimension	NEW STAR 15	352 * 387 * 442
	NEW STAR 30	412 * 474 * 529

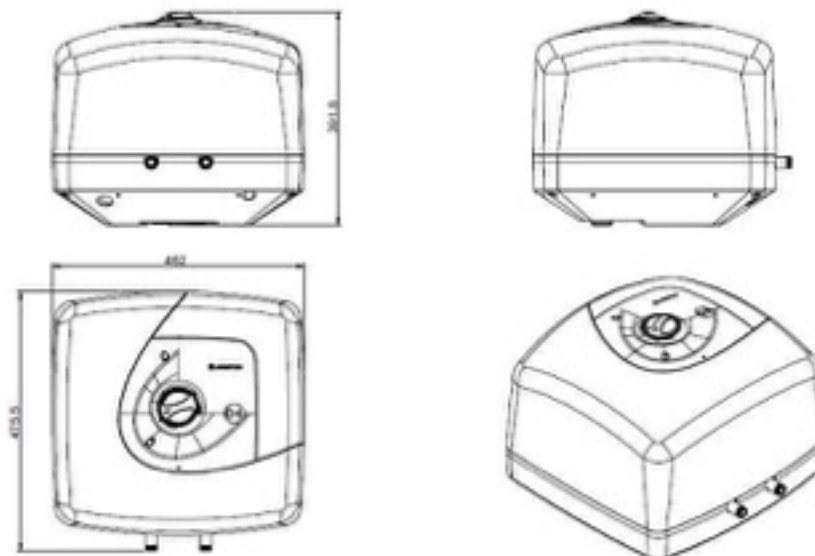

SPECIFICATION DATA

		STAR 15N	STAR 30N
Capacity	Liter	15	30
Power	Watt	2500	2500
Voltage	V	220	220
Heating time ($\Delta T=35^{\circ}\text{C}$)	h;m	0;15	0;31
Max working temp.	$^{\circ}\text{C}$	75	75
Heat Dispersion	kWh/24h	0.56	0.95
Max. Working Pressure	Bar	7.5	7.5
Weight	Kg	7.5	12.8

